



Ducati 1098 / 1098S (2007)

Slip-On Exhaust System

# Akrapovic Slip-On Exhaust System

for the Ducati 1098 / 1098S (2007)

The Akrapovic SLIP-ON OPEN exhaust system for the new Ducati 1098 / 1098S is an invincible combination of performance and price. In addition to performance, the twin titanium or carbon fiber mufflers add a clean racing look. And the Ducati will put out a much more powerful racing sound. You will also save 2.7 kg compared to the stock Ducati exhaust system. The system is for race and track days only and will help you shave your lap times. Therefore it is not homologated for road use.

## PERFORMANCE

Measurements of the Akrapovic SLIP-ON OPEN system on the DUCATI 1098 /1098S without muffler insert:

Power & Torque: the Akrapovic SLIP-ON OPEN system greatly increases the potential of the big twin cylinder engine. Both power and torque are increased over the entire rpm range, with the greatest increase shown in the middle and top of the range. We measured an incredible 151.6 hp at 9810 rpm, while the max. increased power of 6.1 hp was measured at 4800 rpm.

## CONFIGURATION

The Akrapovic SLIP-ON OPEN system for the Ducati 1098 /1098S has a specific 2-2 configuration. The titanium link pipes are welded to the muffler. The header tubes and link pipes are attached with a sleeve joint, secured with a silicon-shielded spring. The muffler is available with a titanium or carbon fiber outer sleeve. The metal interior parts of both mufflers are made entirely of titanium. The outlet cap is made from carbon fiber in both cases. The mufflers are attached to the motorcycle with pair of carbon fiber clamps.

	PERFORMANCE		
	stock	AKRAPOVIC	max. increased power
max. rear wheel power HP / rpm (measured on Dynojet ATV)	148.8 / 9830	151.6 / 9810	6.1 / 4800

	CONFIGURATION		
	header tubes	collector	link pipe
material	-	-	TITANIUM
tube shape	-	-	CYLINDRICAL

interference crossover tubes	-	lambda sensor	NO	
header tube inner sleeves	-	header tube flanges	-	
header tubes - collector connection	-	collector / header tube - link pipe connection	SLEEVE JOINT + SILICON SHIELDED SPRINGS	
link pipe - muffler connection	WELDED	muffler inlet cap /outlet cap	Ti / Carb.-fiber	
muffler metal interior	TITANIUM	muffler outer sleeve	Ti / Carb.-fiber	
muffler clamp	CARBON-FIBER	muffler bracket	-	
muffler insert	EU	YES (track legal)	heat shield	-
	US	-	catalytic converter	-

	ADDITIONAL DATA				
	stock	AKRAPOVIC		difference	
		S.S. link pipe	TITANIUM link pipe	stock - S.S.	stock - titanium
weight comparison (kg)	5.7	-	3.05	-	2.7

noise measurements (dB / rpm)	stock	AKRAPOVIC
	96 / 4875	100.3 / 4875
possibility of periodic service without removing A.E.S.	oil	oil filter
	YES	YES
legal for street use	NO	

Technical specifications of Akrapovic exhaust systems and related products subject to change without notice.

Product code: 107952 (S-D10SO3-ZC)  
107951 (S-D10SO3-ZT)

# Akrapovic Slip-On Exhaust System

for the Ducati 1098 / 1098S (2007)



Akrapovic Exhaust System Technology copyright 2007, all rights reserved

Road  
Program

Product code: 107952 (S-D10SO3-ZC)  
107951 (S-D10SO3-ZT)

# Akrapovic Slip-On Exhaust System for the Ducati 1098 / 1098S (2007)



Akrapovic Exhaust System Technology copyright 2007, all rights reserved

Road  
Program

Product code: 107952 (S-D10SO3-ZC)  
107951 (S-D10SO3-ZT)

# Akrapovic Slip-On Exhaust System for the Ducati 1098 / 1098S (2007)



Akrapovic Exhaust System Technology copyright 2007, all rights reserved

Road  
Program

Product code: 107952 (S-D10SO3-ZC)  
107951 (S-D10SO3-ZT)

# Akrapovic Slip-On Exhaust System

for the Ducati 1098 / 1098S (2007)

DUCATI 1098, SLIP ON OPEN, 2007

Product code: S-D10SO3-ZC  
S-D10SO3-ZT

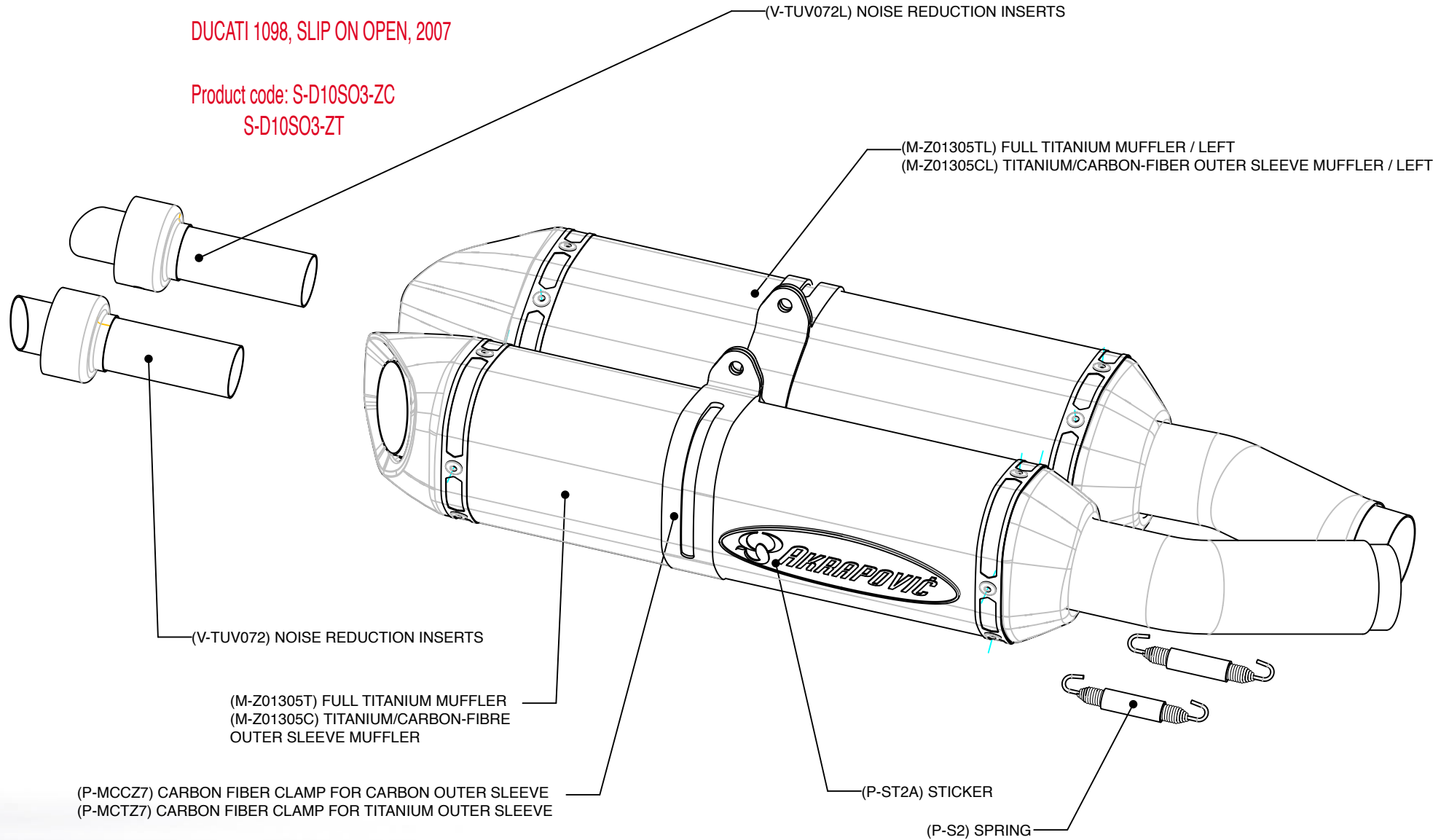

Road Program

Product code: 107952 (S-D10SO3-ZC)  
107951 (S-D10SO3-ZT)

# Akrapovic Slip-On Exhaust System for the Ducati 1098 / 1098S (2007)

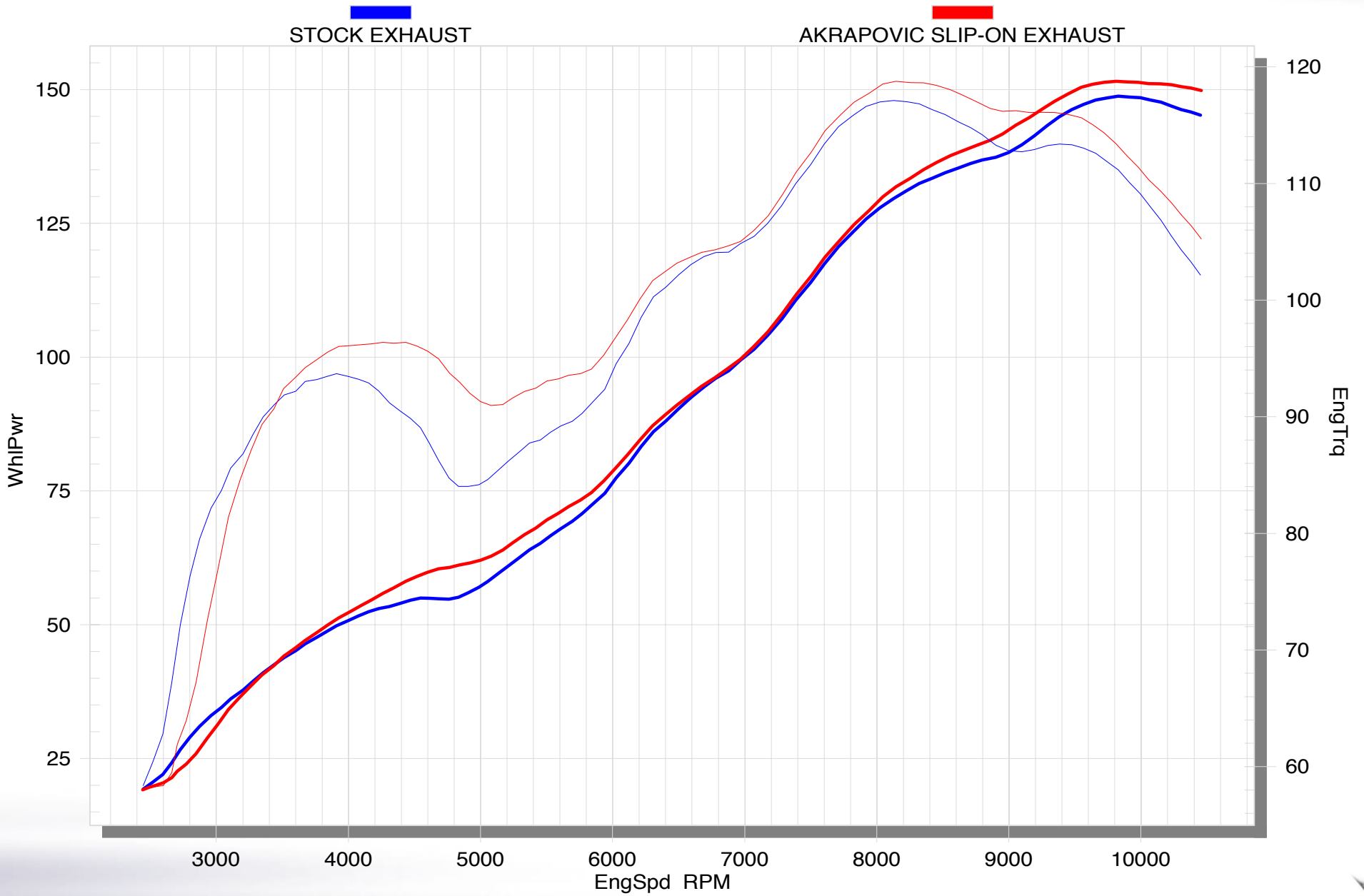

Road Program

Product code: 107952 (S-D10SO3-ZC)  
107951 (S-D10SO3-ZT)



Akrapovic Exhaust System Technology copyright 2007, all rights reserved