

# TB2149 - KTB2149

SCHIENALINO SPECIFICO - SPECIAL BACKREST - DOSSERET SPÉCIFIQUE - SPEZIFISCHE BEIFAHRENER-RÜCKENLEHNE

RESPALDO ESPECÍFICO - APOIO ESPECÍFICO

**YAMAHA**

**X-MAX 300**

**(2017/2020) / YAMAHA**

**TRICITY 300**

**(2020)**

N°	Descrizione/Description	Caratteristiche/Features	Codice/Code	Quantità/Quantity
1	Schienalino - Backrest - Dossieret Beifahrer-rückenlehne - Respaldo - Apoio	-	2111TB	1
2	Supporto - Support - Support Halterung - Soporte - Apoio	Sp. 4mm	GL4518V	1
3	Vite - Screw Vis - Schraube Tornillo - Parafuso	TBEI M8x20	820TBEI	2
4	Vite - Screw Vis - Schraube Tornillo - Parafuso	TBEI M6x20	620TBEI	2
5	Vite - Screw Vis - Schraube Tornillo - Parafuso	TEF M8x70	870TEF	2
6	Rondella spaccata - Split washer Scheibe - Rondelle fendue Arandela seccionada - Arruela Dentada	Foro Ø8mm	Z1060	2
7	Rondella Inox - Stainless Steel Washer Rondelle Inox - Rostfreie Unterlegscheibe Aus Stahl Arandela Inox - Arruela Lisa De Aço Inox	Foro Ø8mm Esterno Ø14mm Sp.0,3mm	805RONX	2
8	Rondella - Washer Rondelle - Scheibe Arandela - Arruela	Foro Ø6mm Esterno Ø18mm Sp.1,5mm	618RON	2
9	Dado a gabbia - Cage nut Écrou cage - Tuerca jaula Halterung für Mutter - Porca especial	M8	8DADIGB	2
10	Dado a gabbia - Cage nut Écrou cage - Tuerca jaula Halterung für Mutter - Porca especial	M6	6DADIGB	2
11	Distanziale - Spacer Entretoise - Distanzstueck Distanciador - Espaçado	Ø10x2 Foro 6,5mm	C10L2F6,5T	2
12	Distanziale - Spacer Entretoise - Distanzstueck Distanciador - Espaçado	Ø18x45 Foro 8,5mm	C18L45F8,5T	2
13	Componenti Originali - Original Parts Parties Originales - Original Bauteile Componentes Originales - Componentes Originais	-	-	-

# TB2149 - KTB2149

SCHIENALINO SPECIFICO - SPECIAL BACKREST - DOSSERET SPÉCIFIQUE - SPEZIFISCHE BEIFAHREER-RÜCKENLEHNE

RESPALDO ESPECÍFICO - APOIO ESPECÍFICO

**YAMAHA**

**X-MAX 300**

(2017/2020) /

**YAMAHA**

**TRICITY 300**

(2020)

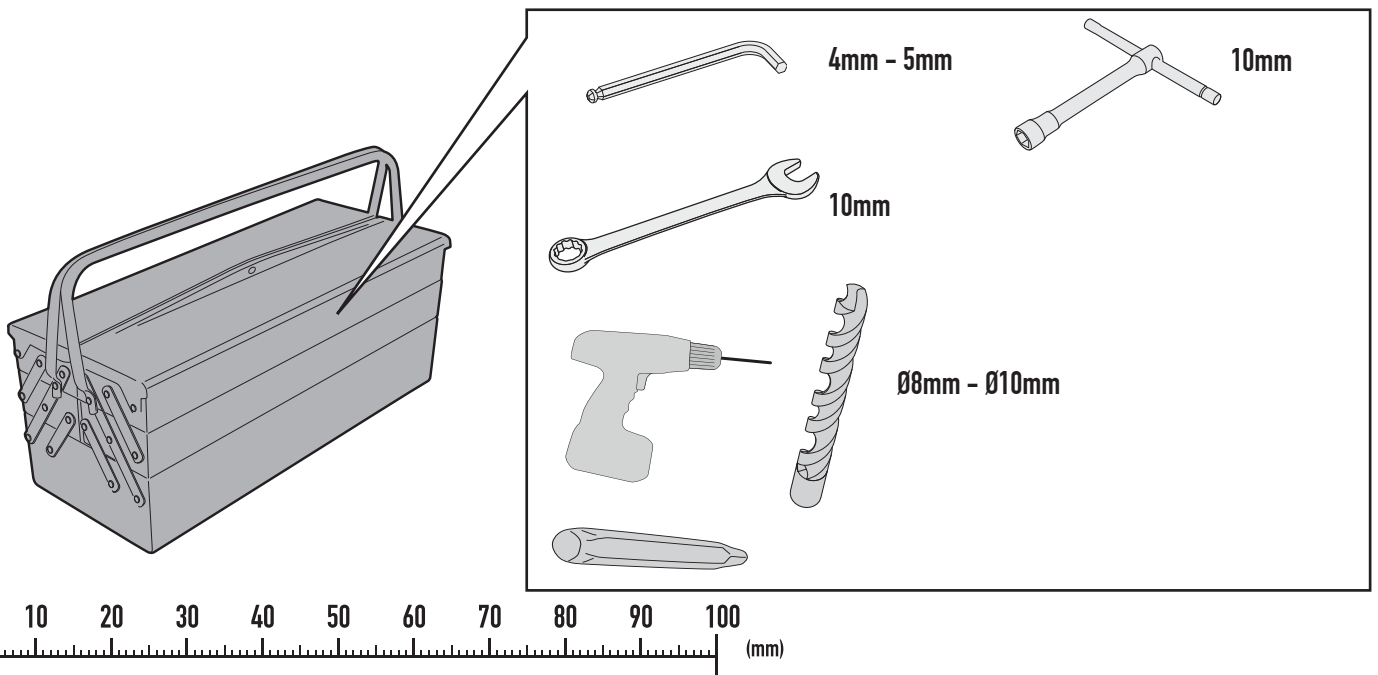
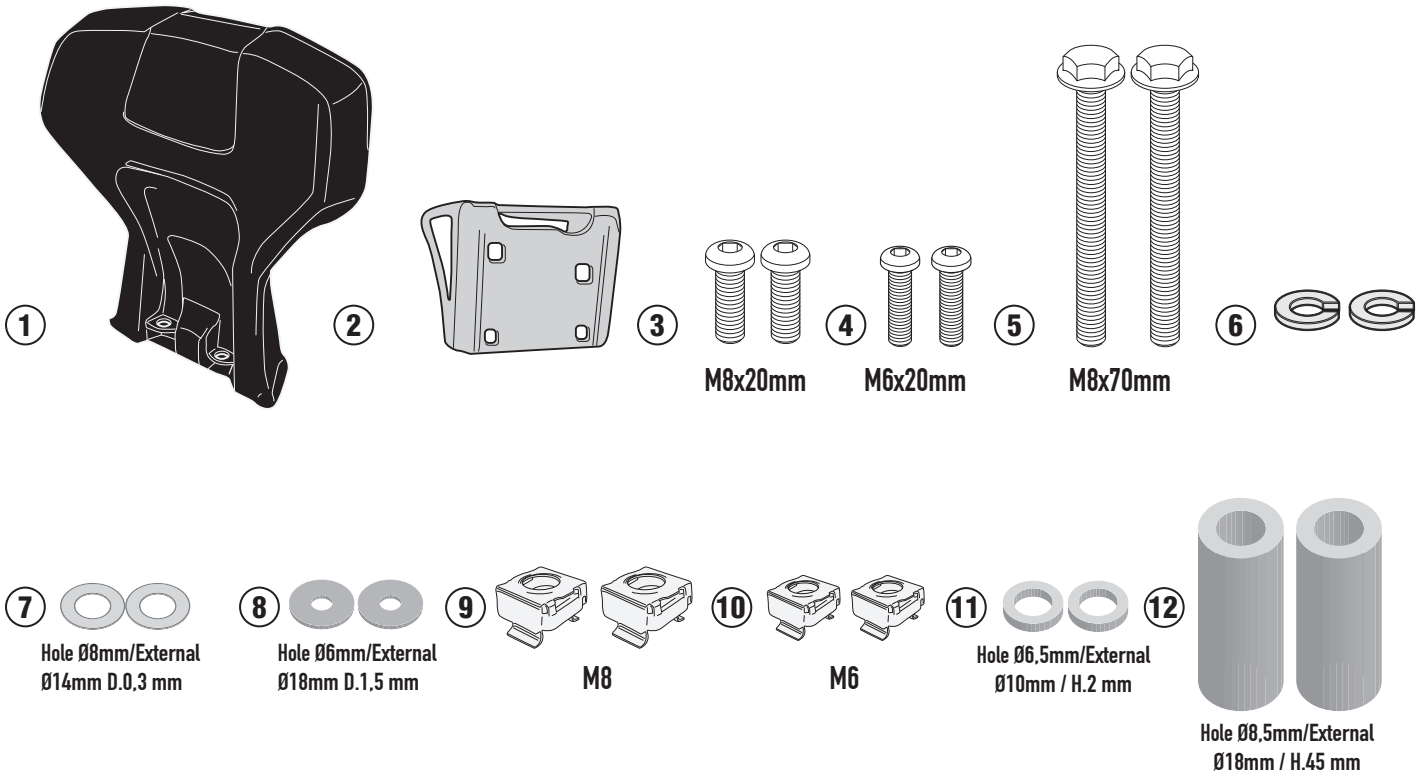

# TB2149 - KTB2149

SCHIENALINO SPECIFICO - SPECIAL BACKREST - DOSSERET SPÉCIFIQUE - SPEZIFISCHE BEIFAHREER-RÜCKENLEHNE

RESPALDO ESPECÍFICO - APOIO ESPECÍFICO

**YAMAHA**

**X-MAX 300**

**(2017/2020)**

**YAMAHA**

**TRICITY 300**

**(2020)**

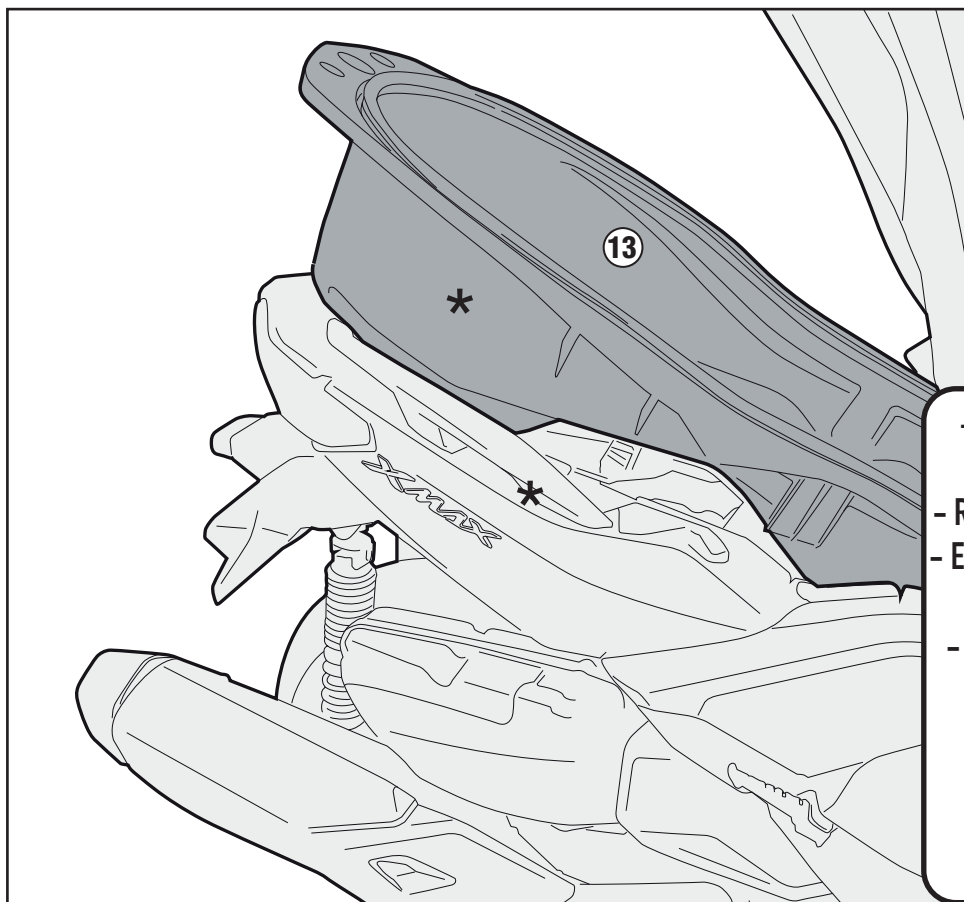

\* TOGLIERE  
REMOVE  
ENLEVER  
ENTFERNEN  
QUITAR  
REMOVE

- RIMUOVERE LE CARENE LATERALI DELLO SCOOTER
- REMOVE THE SIDE FAIRINGS OF THE SCOOTER
- ENTFERNEN SIE DIE SEITENVERKLEIDUNG DES ROLLERS
- DÉMONTER LES CARÉNAGES LATÉRAUX DU SCOOTER
- RETIRAR EL CARENADO LATERAL DEL SCOOTER
- REMOVA OS CARENAGENS LATERAIS DO SCOOTER

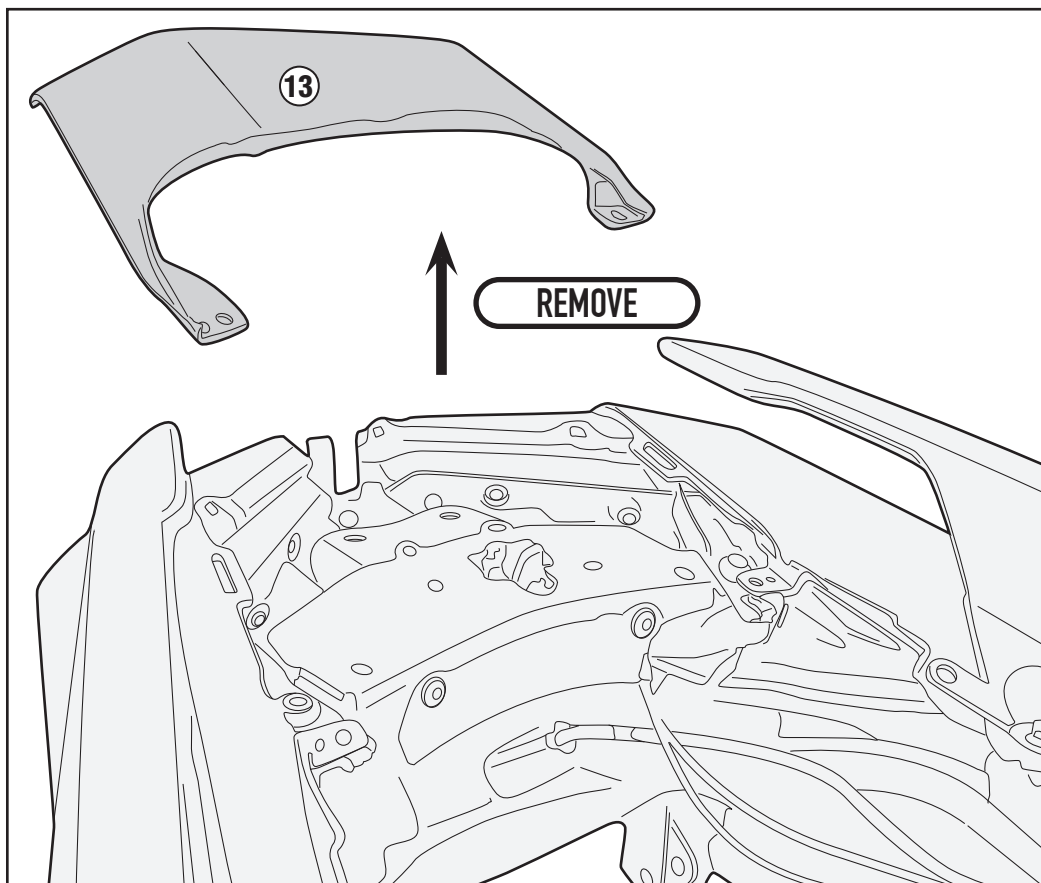

# TB2149 - KTB2149

SCHIENALINO SPECIFICO - SPECIAL BACKREST - DOSSERET SPÉCIFIQUE - SPEZIFISCHE BEIFAHREER-RÜCKENLEHNE

RESPALDO ESPECÍFICO - APOIO ESPECÍFICO

**YAMAHA**

**X-MAX 300**

**(2017/2020)**

**YAMAHA**

**TRICITY 300**

**(2020)**

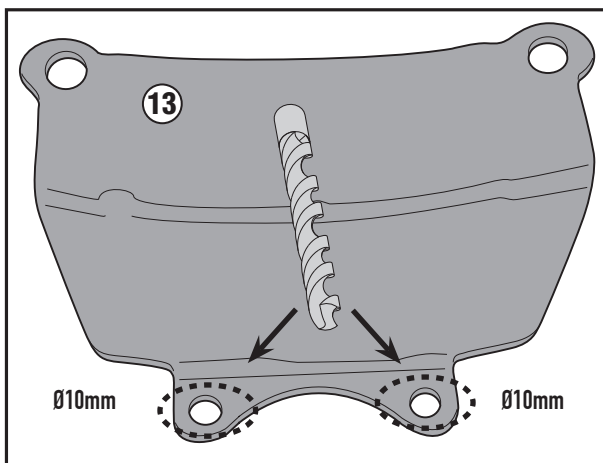
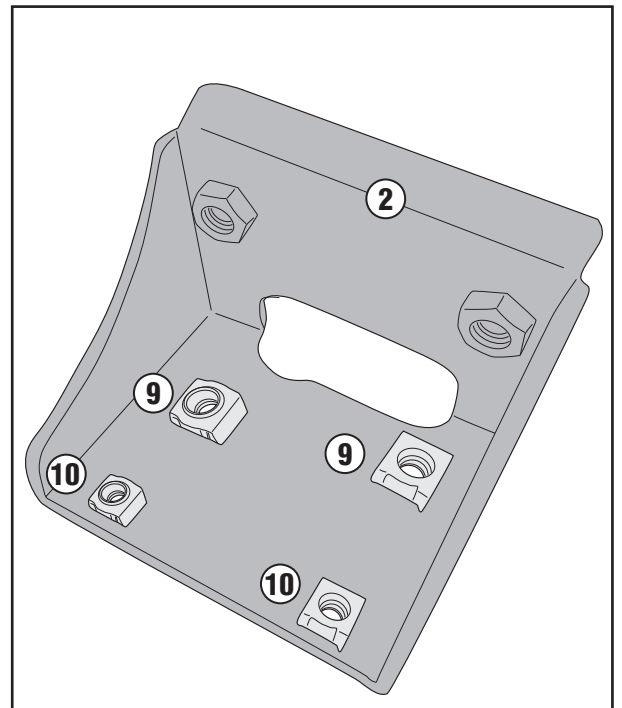
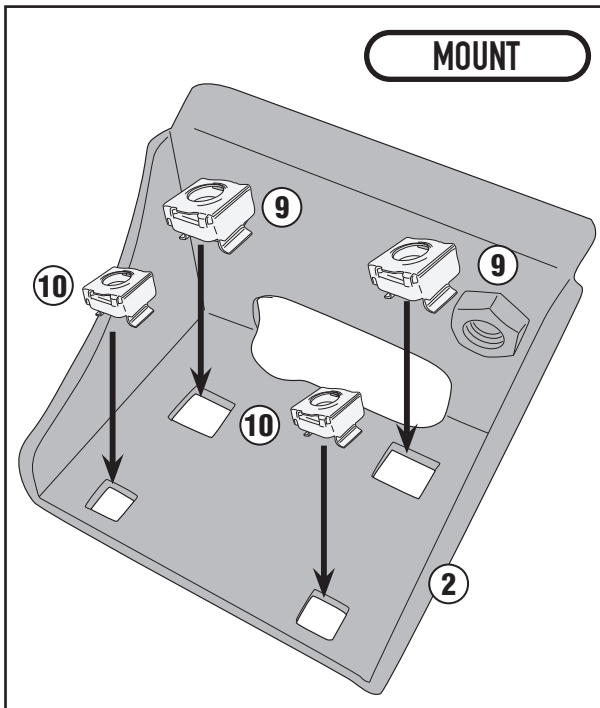

Allargare il foro fino ad un diametro di 10mm.  
Widen the hole to a diameter of 10mm.  
Erweitern Sie die Bohrungen bis zum endgültigen Durchmesser von 10 mm.  
Perçer au diamètre de 10mm.  
Alargar o furo para um diâmetro de 10 milímetros.  
Abrir el agujero hasta un diámetro de 10mm.

# TB2149 - KTB2149

SCHIENALINO SPECIFICO - SPECIAL BACKREST - DOSSERET SPÉCIFIQUE - SPEZIFISCHE BEIFAHRENER-RÜCKENLEHNE

RESPALDO ESPECÍFICO - APOIO ESPECÍFICO

**YAMAHA**

**X-MAX 300**

**(2017/2020)**

**YAMAHA**

**TRICITY 300**

**(2020)**

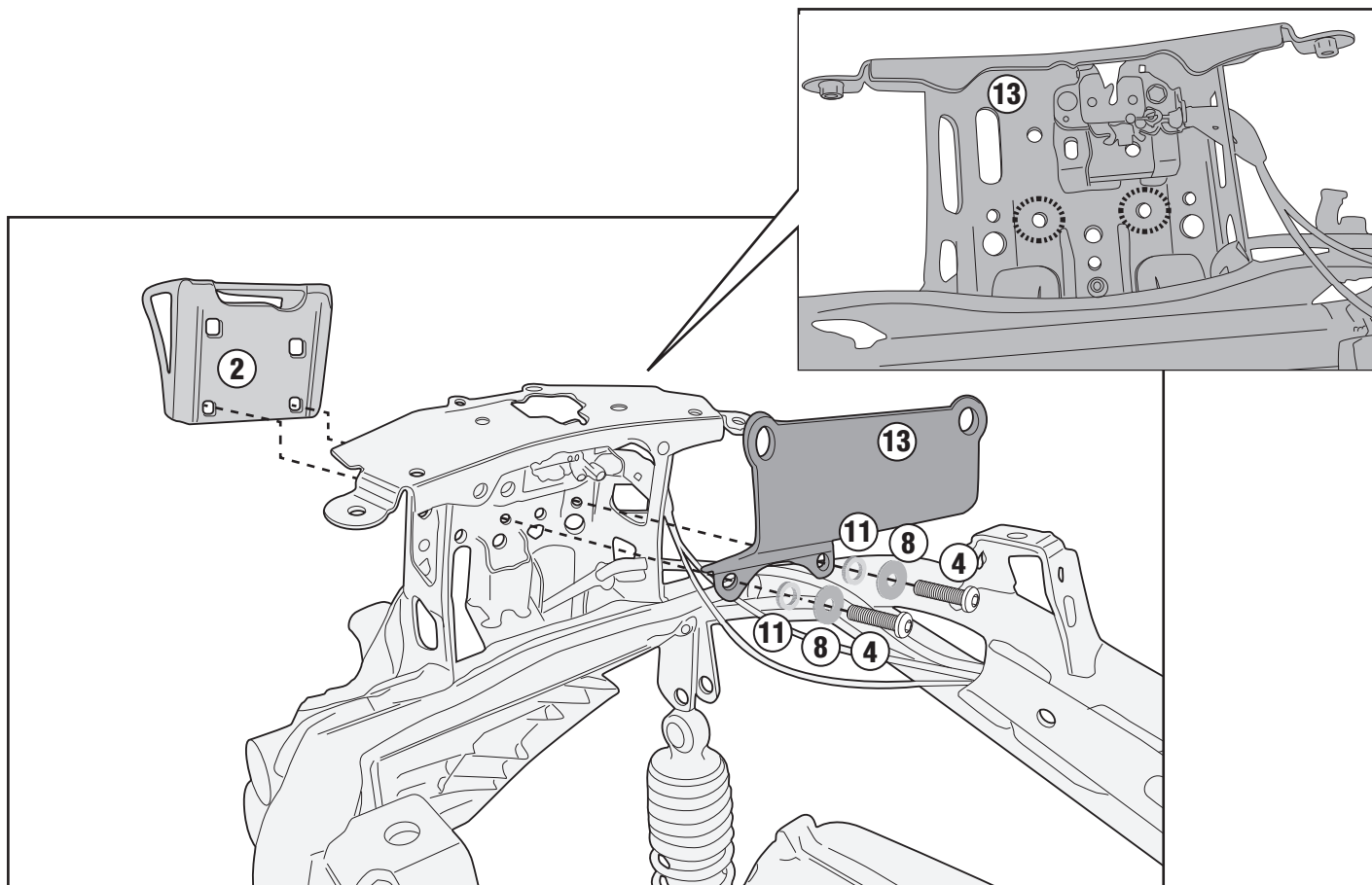
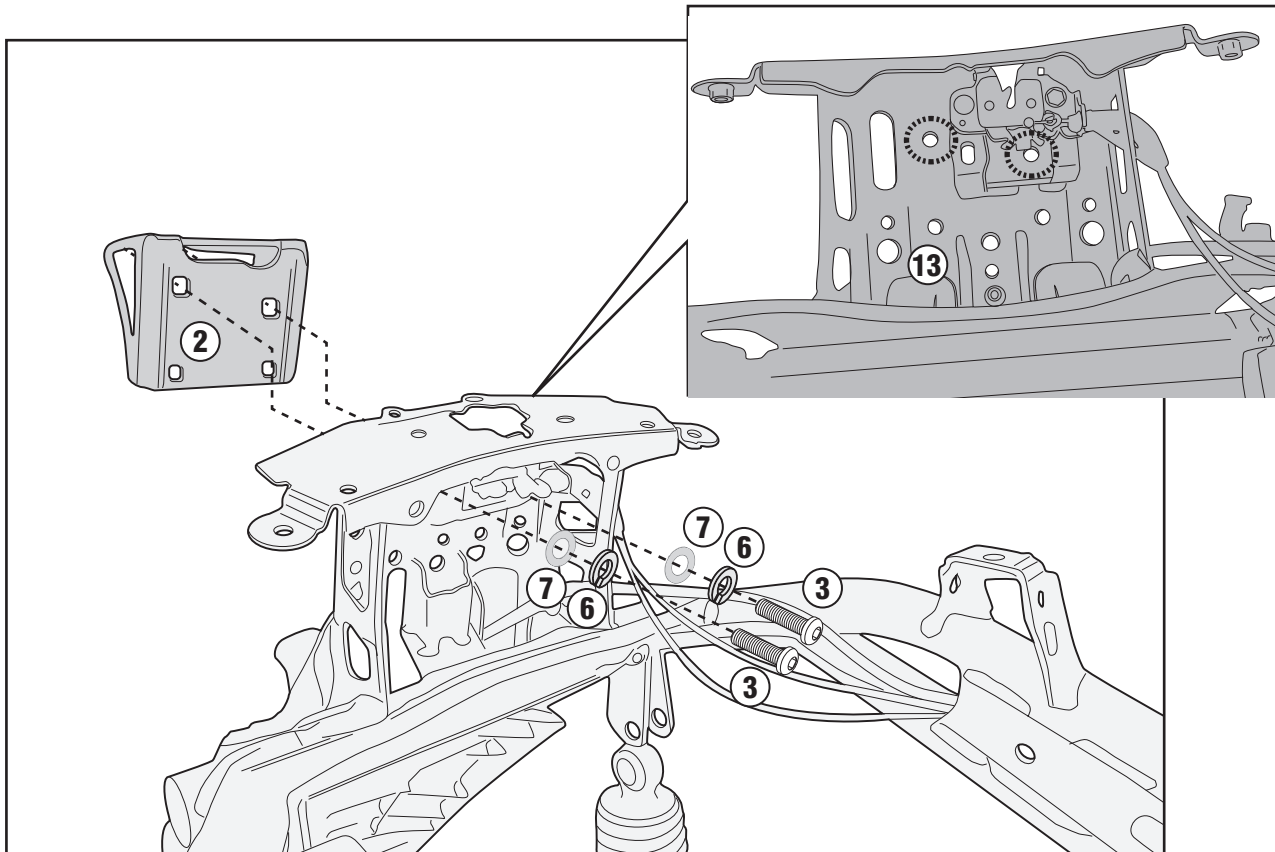

# TB2149 - KTB2149

SCHIENALINO SPECIFICO - SPECIAL BACKREST - DOSSERET SPÉCIFIQUE - SPEZIFISCHE BEIFAHRENER-RÜCKENLEHNE

RESPALDO ESPECÍFICO - APOIO ESPECÍFICO

**YAMAHA X-MAX 300 (2017/2020) / YAMAHA TRICITY 300 (2020)**

**YAMAHA X-TRICITY 300 (2020)**

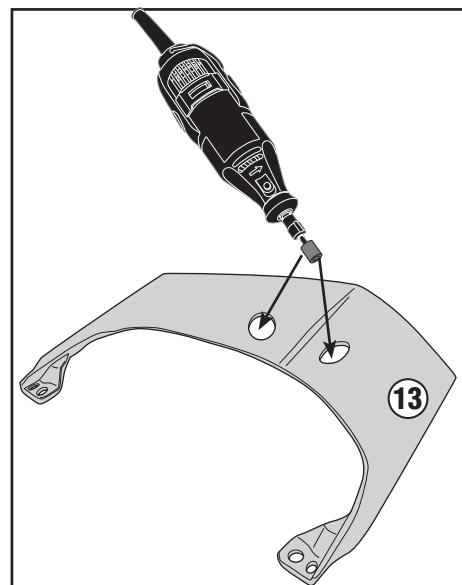
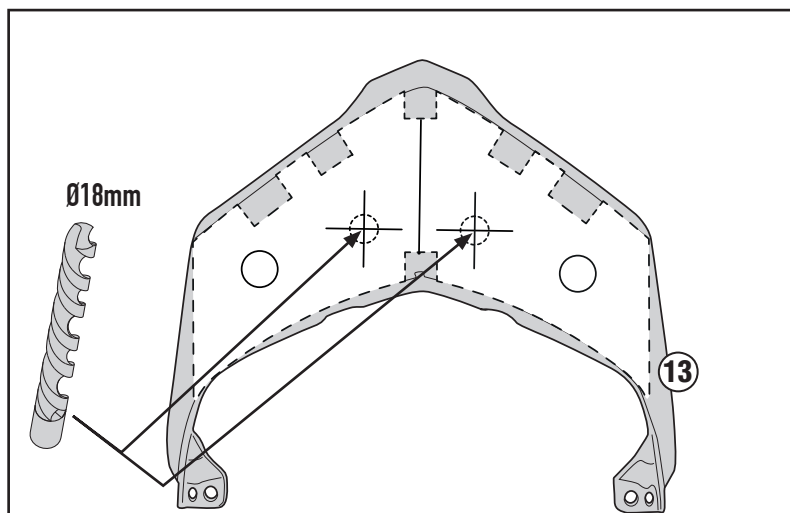
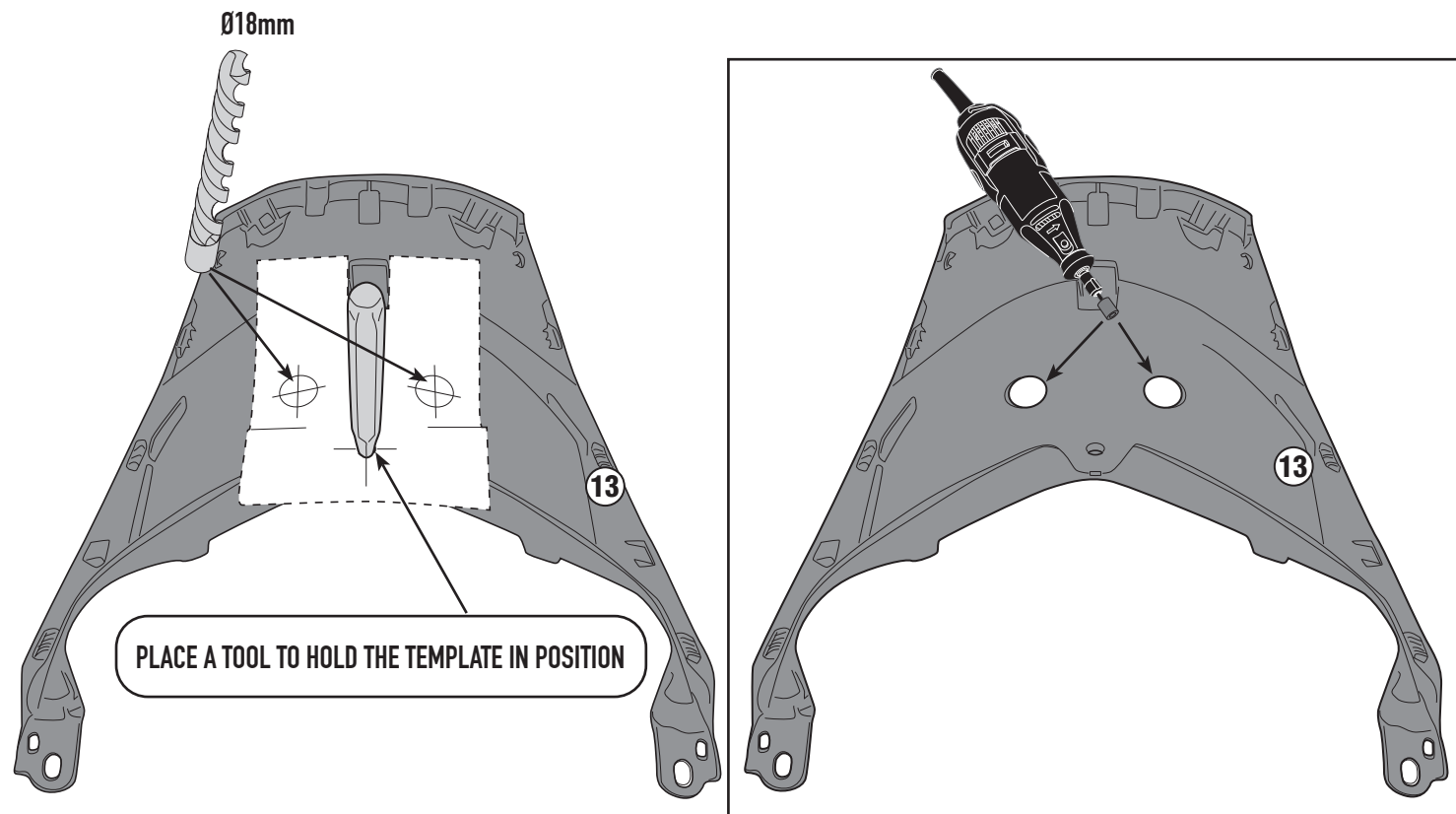

- ASOLARE QUANTO BASTA PER CREARE LA CORRETTA SEDE DEI DISTANZIALI N.9
- USING THE TEMPLATE, MARK THE TWO HOLES TO BE DRILLED. USING A 20MM DRILL BIT, DRILL THE HOLES AND ENLARGE ENOUGH FOR THE SPACERS No.9
- BENUTZEN SIE DIE VORLAGE, UM DIE LÖCHER FÜR DIE BOHRUNG ZU MARKIEREN. NEHMEN SIE EIN 20 MM-BIT, BOHREN SIE DIE LÖCHER, SO DASS DIESE WEIT GENUG FÜR DIE DISTANZHÜLSEN SIND Nr.9
- À L'AIDE DU GABARIT, MARQUEZ LES DEUX TROUS À FORER. EN UTILISANT UN FORET DE 20 MM, PERCEZ LES TROUS DE SORTE QU'ILS SOIENT SUFFISAMMENT GRANDS POUR LES ENTRETOISES n° 9
- TALADRAR LO SUFICIENTE PARA CREAR ESPACIO PARA LOS DISTANCIADORES 9
- USANDO O GABARITO, MARQUE OS DOIS ORIFÍCIOS A SEREM PERFURADOS. USANDO UMA BROCA DE 20MM, PERFURE OS FUROS PARA QUE ELES SEJAM GRANDES O SUFICIENTE PARA OS ESPAÇADORES n°9

ISTRUZIONI DI MONTAGGIO - MOUNTING INSTRUCTIONS  
INSTRUCTIONS DE MONTAGE - BAUANLEITUNG  
INSTRUCCIONES DE MONTAJE - INSTRUÇÕES DE MONTAGEM

# TB2149 - KTB2149

SCHIENALINO SPECIFICO - SPECIAL BACKREST - DOSSERET SPÉCIFIQUE - SPEZIFISCHE BEIFAHREER-RÜCKENLEHNE

RESPALDO ESPECÍFICO - APOIO ESPECÍFICO

**YAMAHA**

**X-MAX 300**

**(2017/2020)**

**YAMAHA**

**TRICITY 300**

**(2020)**

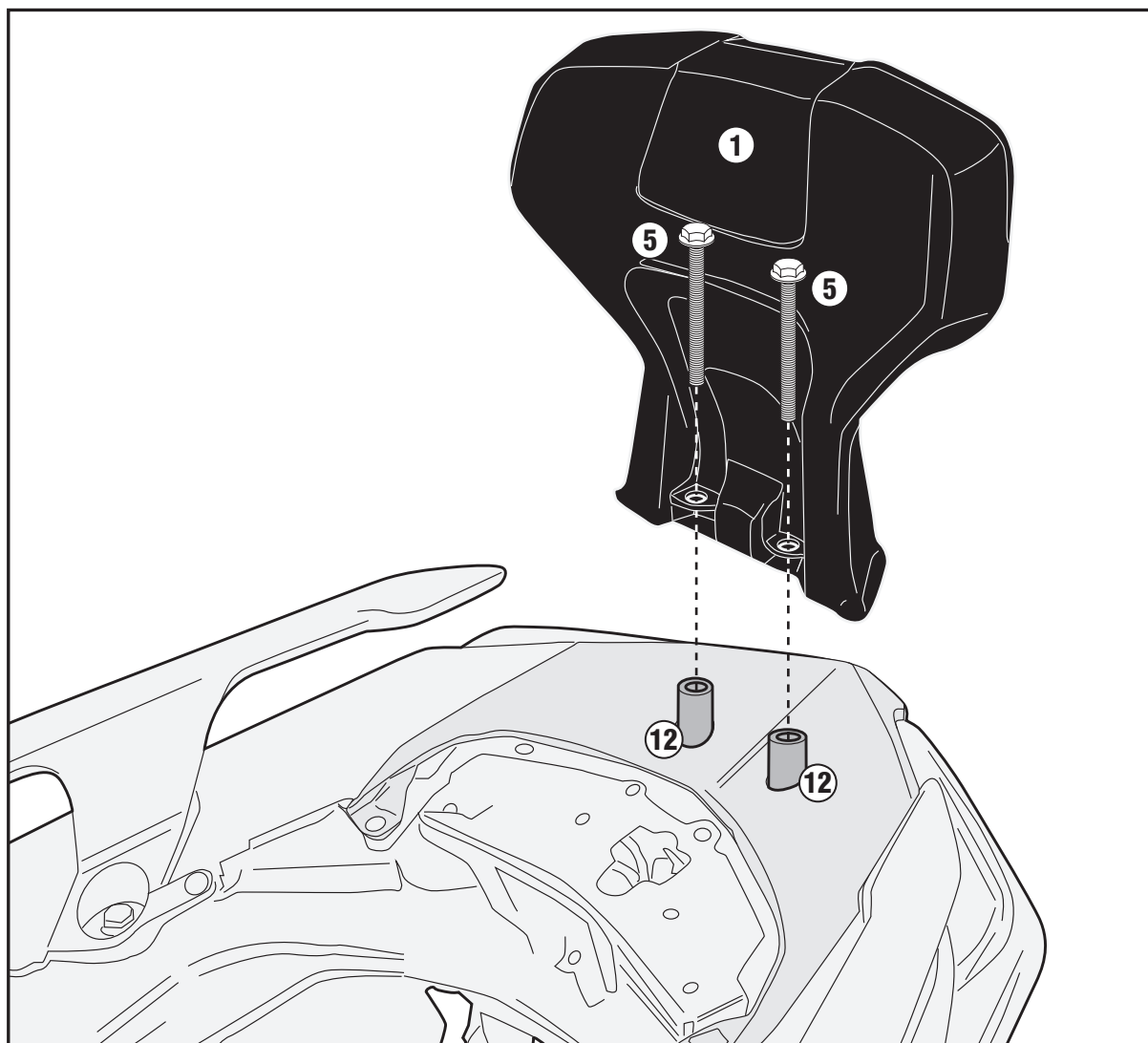
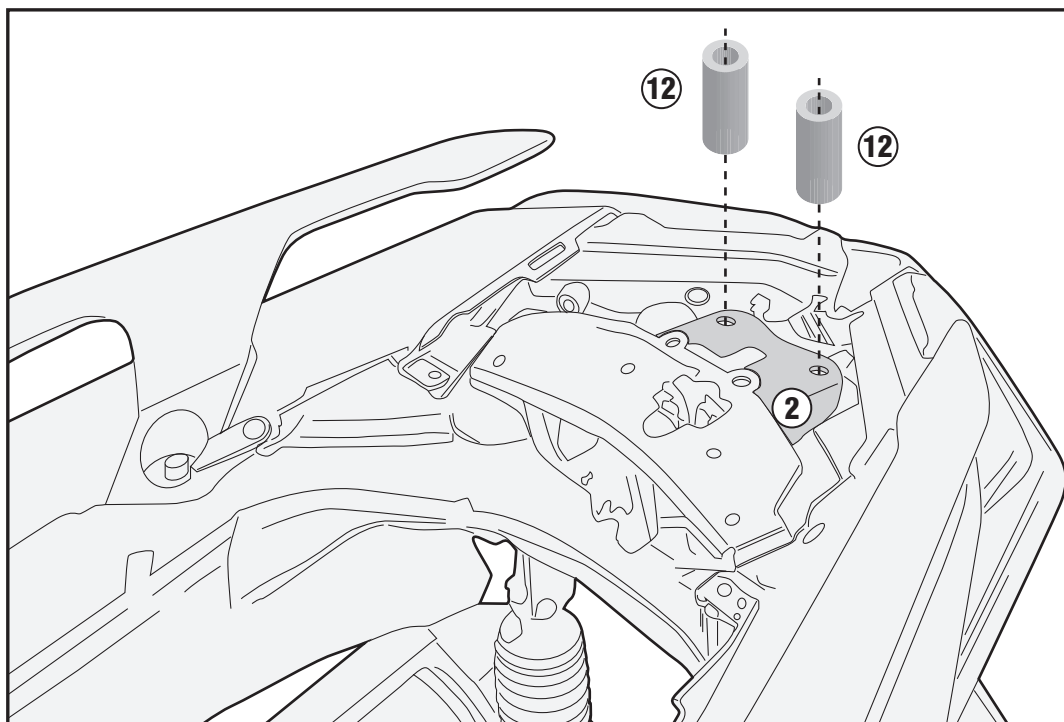

ISTRUZIONI DI MONTAGGIO - MOUNTING INSTRUCTIONS  
INSTRUCTIONS DE MONTAGE - BAUANLEITUNG  
INSTRUCCIONES DE MONTAJE - INSTRUÇÕES DE MONTAGEM

# TB2149 - KTB2149

SCHIENALINO SPECIFICO - SPECIAL BACKREST - DOSSERET SPÉCIFIQUE - SPEZIFISCHE BEIFAHRENER-RÜCKENLEHNE

RESPALDO ESPECÍFICO - APOIO ESPECÍFICO

**YAMAHA**

**X-MAX 300**

**(2017/2020)**

**YAMAHA**

**TRICITY 300**

**(2020)**

---



# TB2149 - KTB2149

SCHIENALINO SPECIFICO - SPECIAL BACKREST - DOSSERET SPÉCIFIQUE - SPEZIFISCHE BEIFAHREER-RÜCKENLEHNE

RESPALDO ESPECÍFICO - APOIO ESPECÍFICO

YAMAHA

X-MAX 300

(2017/2020) /

YAMAHA

TRICITY 300

(2020)

YAMAHA

X-MAX 300

(2017/2020)

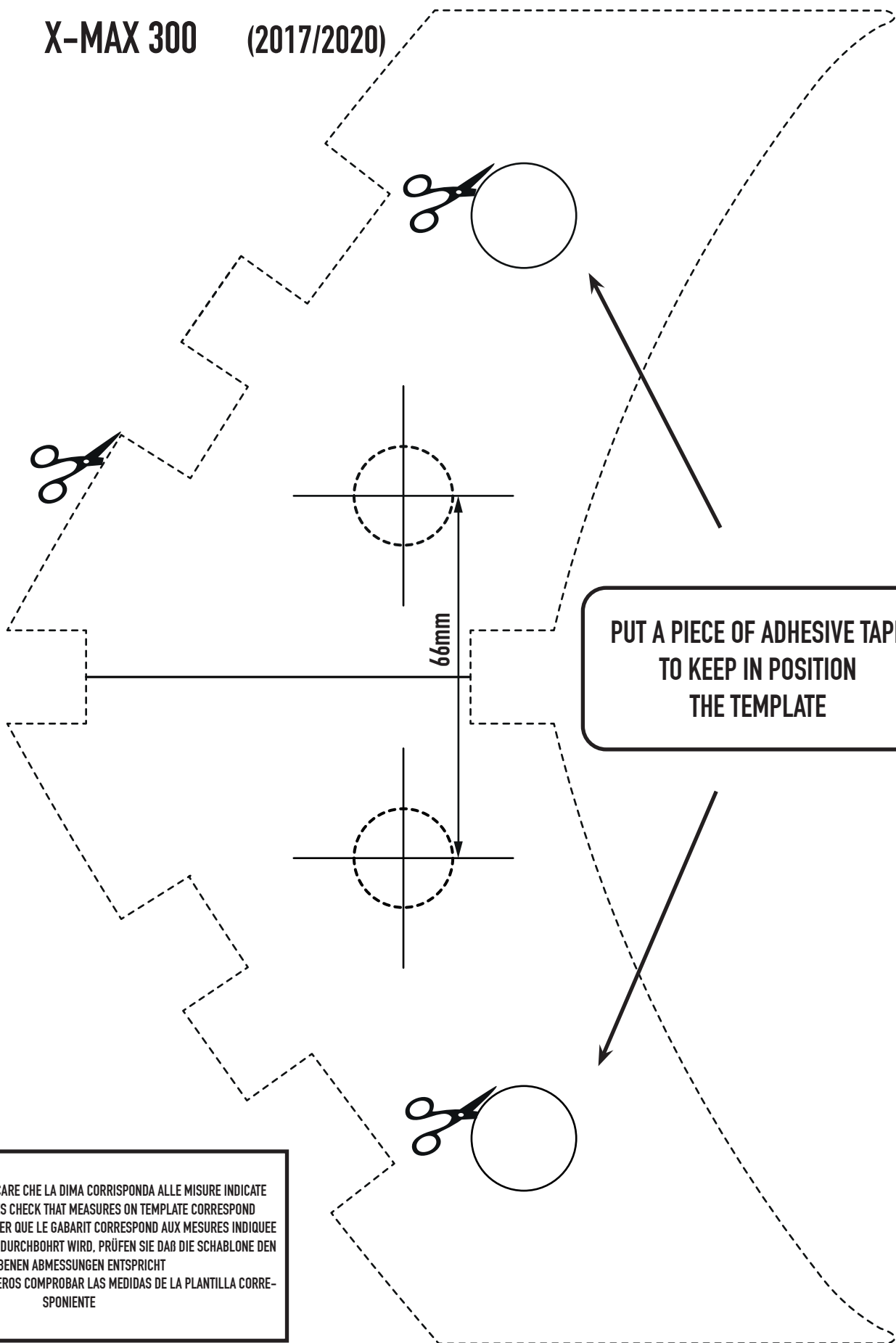

PUT A PIECE OF ADHESIVE TAPE  
TO KEEP IN POSITION  
THE TEMPLATE

. PRIMA DI FORARE VERIFICARE CHE LA DIMA CORRISPONDA ALLE MISURE INDICATE  
. BEFORE DRILLING HOLES CHECK THAT MEASURES ON TEMPLATE CORRESPOND  
. AVANT DE PERCER CONTROLER QUE LE GABARIT CORRESPOND AUX MESURES INDIQUEE  
. BEVOR DER KOFFERDECKEL DURCHBOHRT WIRD, PRÜFEN SIE DAB DIE SCHABLONE DEN  
GEGEBENEN ABMESSUNGEN ENTSPRICH  
. ANTES DE HACER LOS AGUJEROS COMPROBAR LAS MEDIDAS DE LA PLANTILLA CORRE-  
SPONIENTE

# TB2149 - KTB2149

SCHIENALINO SPECIFICO - SPECIAL BACKREST - DOSSERET SPÉCIFIQUE - SPEZIFISCHE BEIFAHREER-RÜCKENLEHNE

RESPALDO ESPECÍFICO - APOIO ESPECÍFICO

YAMAHA

X-MAX 300

(2017/2020) /

YAMAHA

TRICITY 300

(2020)

YAMAHA

X-TRICITY 300

(2020)

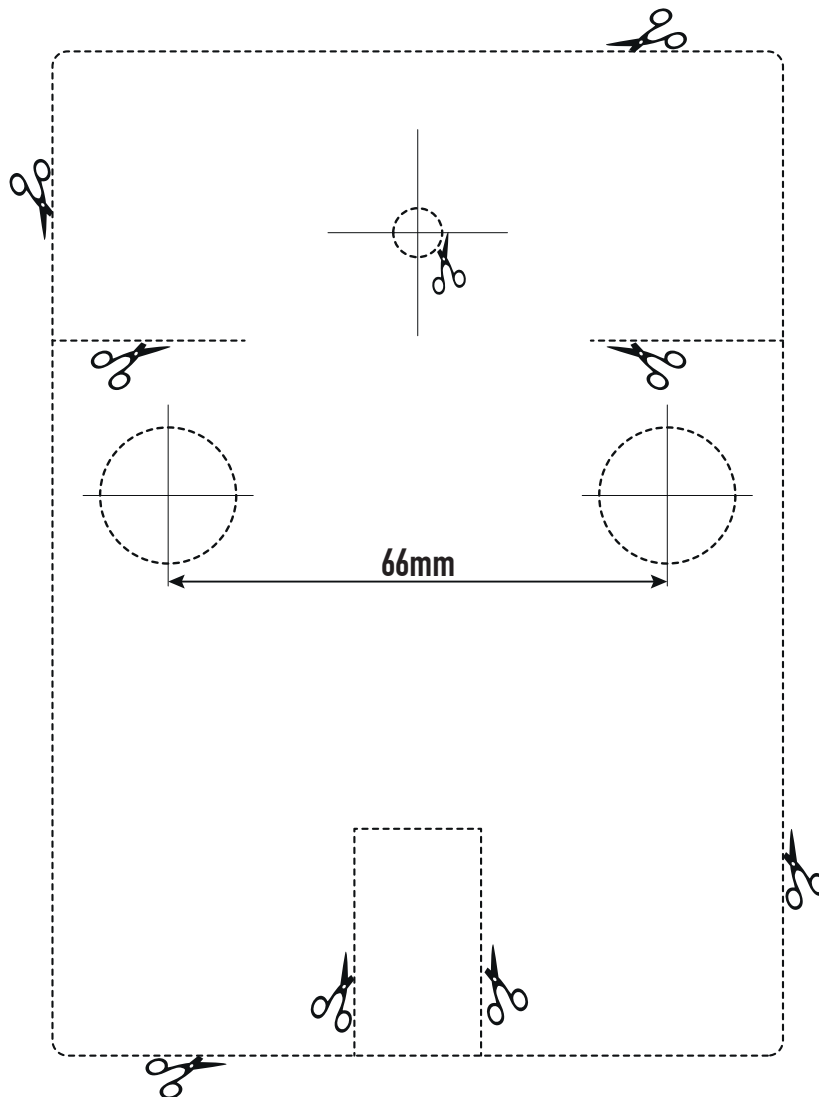

- . PRIMA DI FORARE VERIFICARE CHE LA DIMA CORRISPONDA ALLE MISURE INDICATE
- . BEFORE DRILLING HOLES CHECK THAT MEASURES ON TEMPLATE CORRESPOND
- . AVANT DE PERCER CONTROLER QUE LE GABARIT CORRESPOND AUX MESURES INDIQUEE
- . BEVOR DER KOFFERDECKEL DURCHBOHRT WIRD, PRÜFEN SIE DAB DIE SCHABLONE DEN GEGEBENEN ABMESSUNGEN ENTSpricht
- . ANTES DE HACER LOS AGUJEROS COMPROBAR LAS MEDIDAS DE LA PLANTILLA CORRESPONIENTE